

2/2-way valves DN 8 to DN 50
for neutral gaseous and liquid fluids
Indirectly solenoid actuated
Piston valves
Internal threads G 1/4 to G 2 or 1/4" NPT to 2" NPT
Operating pressure 0,5 to 40 bar

85 300
85 310

40 bar
Click-on®

Description (standard valve)

Solenoid valve for e.g. air, water

Switching function:	Normally closed
Flow direction:	determined
Fluid temperature:	-10 °C up to max. +90 °C
Ambient temperature:	-10 °C up to max. +50 °C
Mounting position:	optional, preferably solenoid vertical on top



Material

Body:	Brass
Seat seal:	NBR (Perbunan)
Internal parts:	Stainless steel, Brass, PTFE

For contaminated fluids insertion of a strainer is recommended (see accessories).

Features

- Compact piston valve
- High flow rate
- Damped operation
- Simple compact design
- Solenoid in Click-on® design
- Stainless steel piston bushing

Symbol

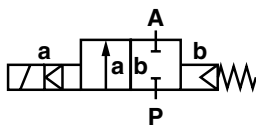

Ordering information

To order, quote model number from table overleaf, e.g . 85 300 00.9151 for a G 1/4 valve with standard solenoid.

Characteristic data

See page 2 valve and solenoid informations

Characteristic data
Valves

Part Number. with DC or AC solenoid	Nominal Diameter (mm)	Port Size	Length (mm)	Operating Pressure *		kv-value ** (Base m ³ /h)	Weight (kg)
				min	max (bar)		
85 300 00.9151 85 310 00.9151	8	G 1/4 1/4" NPT	60	0,5	40	2,2	0,83
85 301 00.9151 85 311 00.9151	10	G 3/8 3/8" NPT	60	0,5	40	3,4	0,82
85 302 00.9151 85 312 00.9151	12	G 1/2 1/2" NPT	67	0,5	40	4,4	0,85
85 303 00.9151 85 313 00.9151	20	G 3/4 3/4" NPT	80	0,5	40	7,0	1,25
85 304 00.9151 85 314 00.9151	25	G 1 1" NPT	95	0,5	40	10,5	1,70
85 305 00.9151 85 315 00.9151	32	G 1 1/4 1 1/4" NPT	132	0,5	40	25,0	4,10
85 306 00.9151 85 316 00.9151	40	G 1 1/2 1 1/2" NPT	132	0,5	40	27,0	3,85
85 307 00.9151 85 317 00.9151	50	G 2 2" NPT	160	0,5	40	43,0	5,60

* with gaseous and liquid fluids up to 40 mm²/s (cSt)

State voltage [V] and frequency [Hz]

** C_v-value (US) ≈ kv-value x 1,2

9151 Solenoid
Standard voltages

DC	AC	
	50 Hz	60 Hz
24 V	24 V	–
–	110 V	120 V
–	230 V	220 V

Design acc. to VDE 0580

Voltage range ±10 %

100 % duty cycle

Protection class acc. to EN 60529 IP 65 (previous DIN 40050)

Socket acc. to DIN 43 650-A Pg11

Options (Valves)

XX XXX 01 .XXXX	Normally open (NO)
XX XXX 02 .XXXX	Manual override
XX XXX 03 .XXXX	Seat seal FPM, max. fluid temperature +110 °C
XX XXX 14 .XXXX	Seat seal EPDM, for hot water, max. fluid temperature +110 °C

On request

Further versions

Power Consumption

According to VDE 0580 at coil temperature +20 °C. In operating the solenoid coil decrease the power consumption appr. 30 %.

DC	AC	
	Inrush	Holding
18 W	45 VA	35 VA / 17 W

For technical details see catalogue-register "Solenoids"

Section View

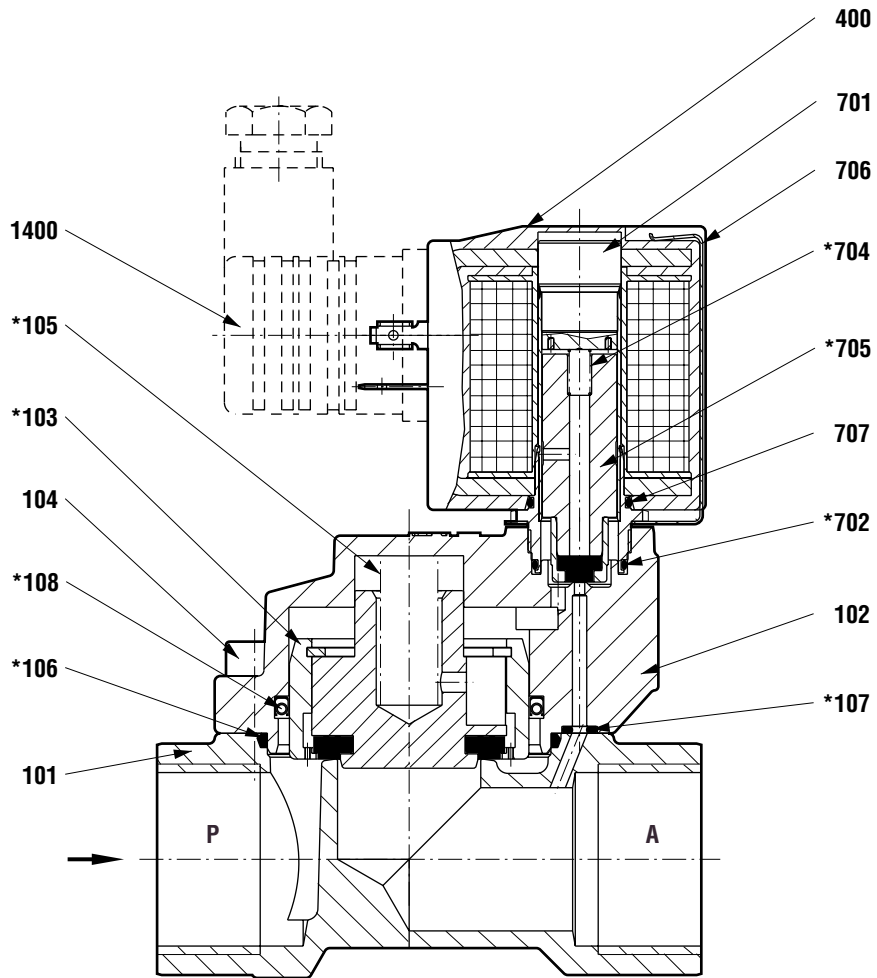

- 101 Valve body
- 102 Valve cover
- *103 Valve piston
- 104 Cheese head cap screw
- *105 Pressure spring
- *106 Seal ring
- *107 O-ring
- *108 Grooved ring

- 400 Solenoid
- 701 Core tube
- *702 O-ring
- *704 Pressure spring
- *705 Core
- 706 Spring clip
- 707 O-ring
- 1400 Socket (included)

* These individual parts form a complete wearing unit.
When ordering spare parts please state Cat No and Series No.

General Dimensions

Solenoid rotatable 360°
 Socket turnable 4 x 90°
 (Socket included)

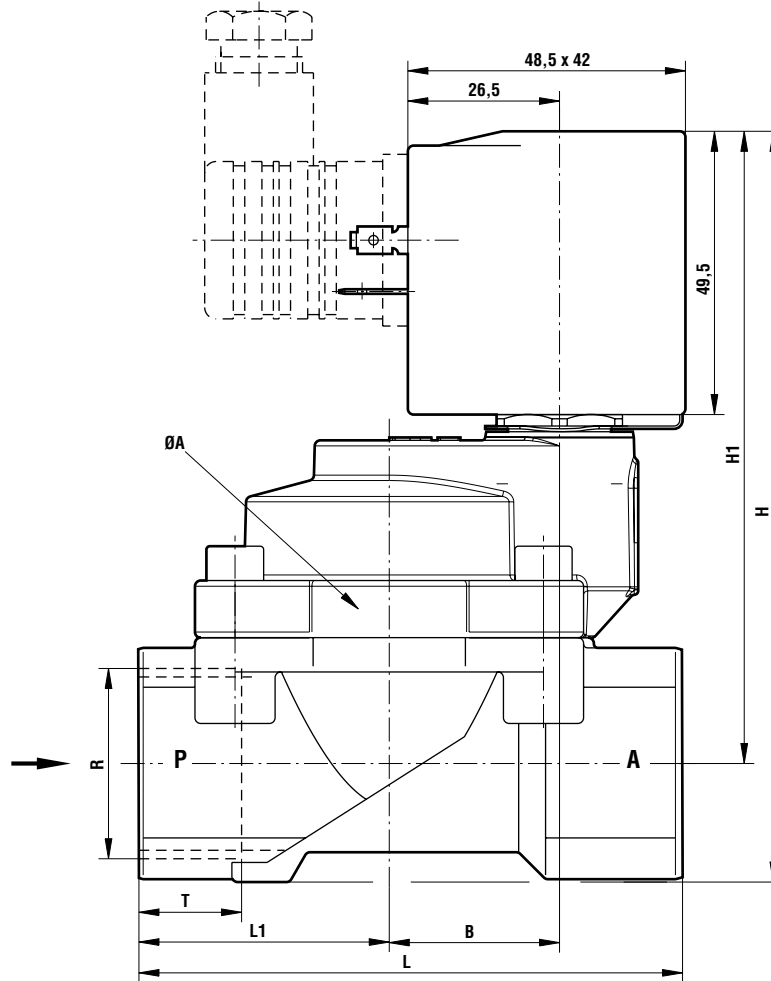

Part Number	Ø A	B	H	H1	L	L1	R	T
85 300 00.9151	44	19,5	105,0	93,5	60	27,5	G 1/4	12,0
85 310 00.9151							1/4" NPT	10,0
85 301 00.9151	44	19,5	105,0	93,5	60	27,5	G 3/8	12,0
85 311 00.9151							3/8" NPT	10,5
85 302 00.9151	44	19,5	107,5	93,5	67	31,0	G 1/2	14,0
85 312 00.9151							1/2" NPT	13,5
85 303 00.9151	50	24,0	119,0	102,5	80	36,5	G 3/4	16,0
85 313 00.9151							3/4" NPT	14,0
85 304 00.9151	62	29,5	131,5	110,5	95	44,0	G 1	18,0
85 314 00.9151							1" NPT	17,0
85 305 00.9151	92	44,5	166,0	137,0	132	60	G 1 1/4	20,0
85 315 00.9151							1 1/4" NPT	17,0
85 306 00.9151	92	44,5	166,0	137,0	132	60	G 1 1/2	22,0
85 316 00.9151							1 1/2" NPT	17,0
85 307 00.9151	109	54,5	186,0	151,5	160	74	G 2	24,0
85 317 00.9151							2" NPT	17,5

EU Manufacturer's Declaration
as defined in EU Machinery Guideline 89/392/EEC, Appendix II B
 We hereby declare that the diaphragm valves were developed and designed using the following harmonised standards:

- EN 292 Machine Safety**
- EN 983 Pneumatic Systems**
- EN 60204-1 Electrical Equipment for Machinery**

Note
 These piston valves are intended for fitting in a machine. They must not be commissioned until it has been established that the machine as a whole conforms to the EU guideline.

Note on EU guideline
 The valves shall be provided with an electrical circuit which ensures the limits of the harmonised standards EN 50081-1 and EN 50082-1 are observed, and hence the requirements of the Electromagnetic Compatibility Guideline (89/336/EEC) satisfied.