

Temposonics®

Magnetostrictive Linear-Position Sensors

R-Series Model RP and RH Sensors
EtherCAT® Industrial Ethernet Interface

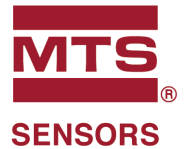

551074 A

Product Specification

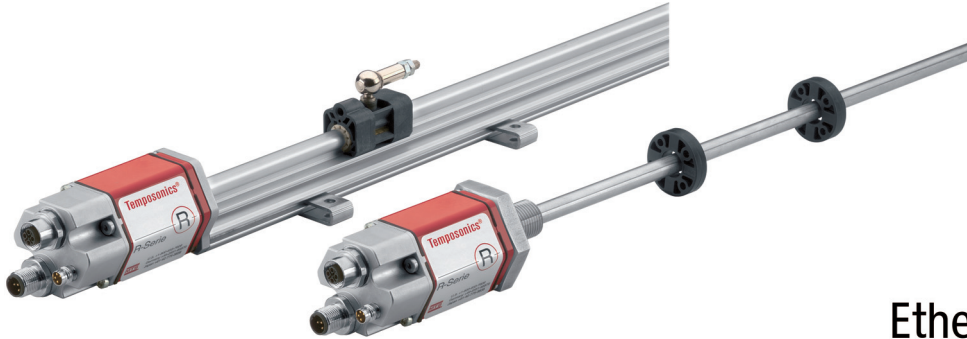

- Rugged industrial sensor
- Linear, absolute measurement
- LEDs for sensor diagnostics
- Non-contact sensing technology
- Superior accuracy, resolution up to 5 µm
- 100 µsec update rate
- Non-linearity less than 0.01%
- Repeatability within 0.001%
- Direct EtherCAT interface, displacement + speed
- Multi-magnet position measurement (up to 4 positions per sensor)

LED diagnostics

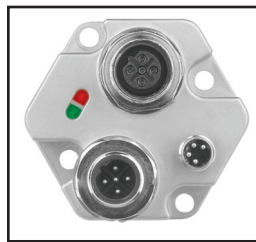

R-Series linear-position sensors

- R-Series model RH and RP sensors are extremely robust and are ideal for continuous operation under harsh industrial conditions.
- Two standard sensor housings are available. The rod housing is capable of withstanding high pressures such as those found in hydraulic cylinders. The profile extrusion housing provides convenient mounting options and sliding magnets.
- The sensor head contains the active signal conditioning and a complete integrated electronics interface. Double shielding is used to ensure EMI protection for unsurpassed reliability and operating safety.

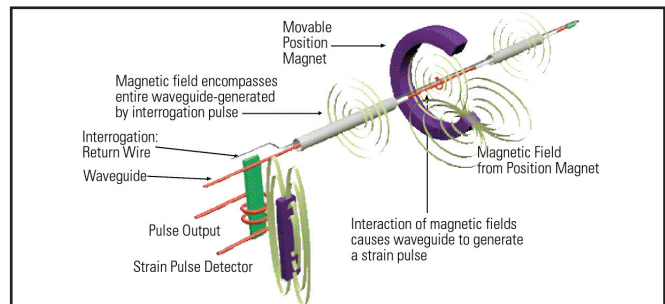

The benefits of magnetostrictive sensing

Temposonics linear sensors use the time-based magnetostrictive position sensing principle developed by MTS. Within the sensing element, a sonic strain pulse is induced in a specially designed magnetostrictive waveguide by the momentary interaction of two magnetic fields. One field comes from a movable permanent magnet that passes along the outside of the sensor. The other field comes from an “interrogation” current pulse applied along the waveguide. The resulting strain pulse travels at ultrasonic speed along the waveguide and is detected at the head of the

sensing element. The position of the magnet is determined with high precision and speed by accurately measuring the elapsed time between the application of the interrogation pulse and the arrival of the resulting strain pulse with a high speed counter. Using the elapsed time to determine position of the permanent magnet provides an absolute position reading that never needs recalibration or re-homing after a power loss. Non-contact sensing eliminates wear, and guarantees the best durability and output repeatability.



All specifications are subject to change. Please contact MTS for specifications that are critical to your needs.

High-speed networked sensors with enhanced monitoring and diagnostics

EtherCAT interface

Temposonics R-Series EtherCAT sensors represent MTS Sensors' latest development in high-speed networked position feedback. EtherCAT (Ethernet for Control Automation Technology)* is a unique interface for industrial Ethernet that provides the fastest, most deterministic industrial networking solution possible using the base Ethernet physical layer. By using this format, coupled with our high speed networked sensing capability, machine builders and automation engineers will be able to overcome bandwidth and node limitation issues found with other commercially available industrial networks.

* Developed by Beckhoff Automation and supported by the EtherCAT Technology Group (ETG)

Sensor status and diagnostic display

Integrated LEDs (green/red) provide basic visual feedback for normal sensor operation and troubleshooting including missing or out of range magnet and network status and activity.

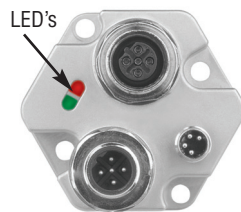

EtherCAT operation modes

EtherCAT sensors provide measurements using one or multiple magnets. The following operation modes are available:

- Standard measurement:
 - Position and speed measurement (using one magnet)
- Multi-magnet measurement:
 - Position and speed of four magnets maximum.

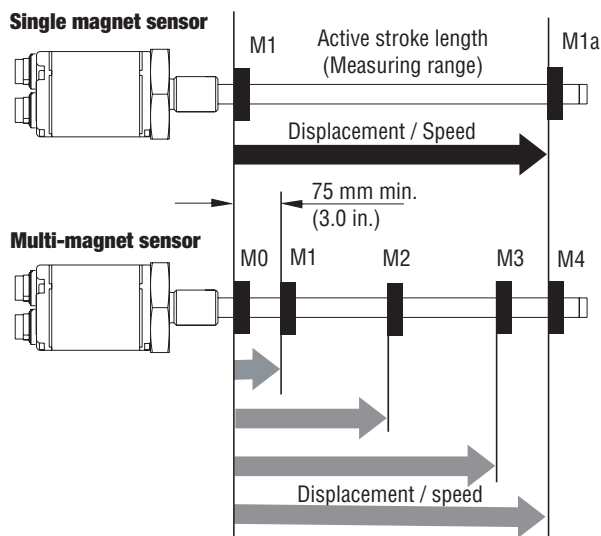

Parameters Specification

Parameters	Specification
Measured variable:	Displacement, speed / optional: multi-magnet measurements (up to 4 magnet positions + velocities)
Resolution:	Displacement: 5 µm Speed: 0.2 mm/sec
Update time (one magnet):	0.1 ms (independent of stroke range)
Non-linearity:	< ± 0.01% full scale (minimum ± 40 µm)
Repeatability:	< ± 0.001% full scale (minimum ± 2.5 µm) Hysteresis: < 4 µm
Outputs:	Interface: EtherCAT Data format: IEEE 802.3 based Data transmission rate: 100 Mbit/s max.
Measuring range:	Profile style: 50 to 5080 mm (2 to 200 in.) Rod style: 50 to 7620 mm (2 to 300 in.)
Operating voltage:	+24 Vdc nominal (-15 or +20%) Polarity protection: up to -30 Vdc Overvoltage protection: up to 36 Vdc Current drain: 100 mA maximum Dielectric withstand voltage: 500 Vdc (DC ground to machine ground)
Operating conditions:	Temperature: -40 to +75 °C, (-40 to +167 °F) Relative humidity: 90% no condensation Temperature coefficient: < 15 ppm / °C
EMC test:	Emissions IEC/EN 50081-1, Immunity IEC/EN 50082-2, IEC/EN 61000-4-2/3/4/6, level 3/4 criterium A, CE qualified
Shock rating:	100 g (single hit)/IEC standard 68-2-27 (survivability)
Vibration rating:	15 g/10-2000 Hz/IEC standard 68-2-6
Connection type:	D56 option: 2 x 5-pin connectors (M12) one male, one female, plus 1 x 4-pin connector (M8) male.

Bus connections

D56 connector option for "daisy chain" topologies

A separate cable is used for the bus and for the supply voltage.

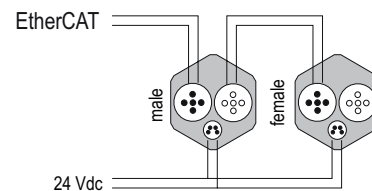

D56 connector option with the "T" connector

A "T" connector is used with the separate bus cable to enable the bus to remain active when a sensor is disconnected.

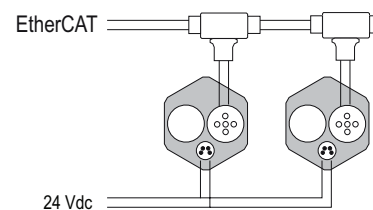

Model RP profile-style sensor

Captive-sliding magnet

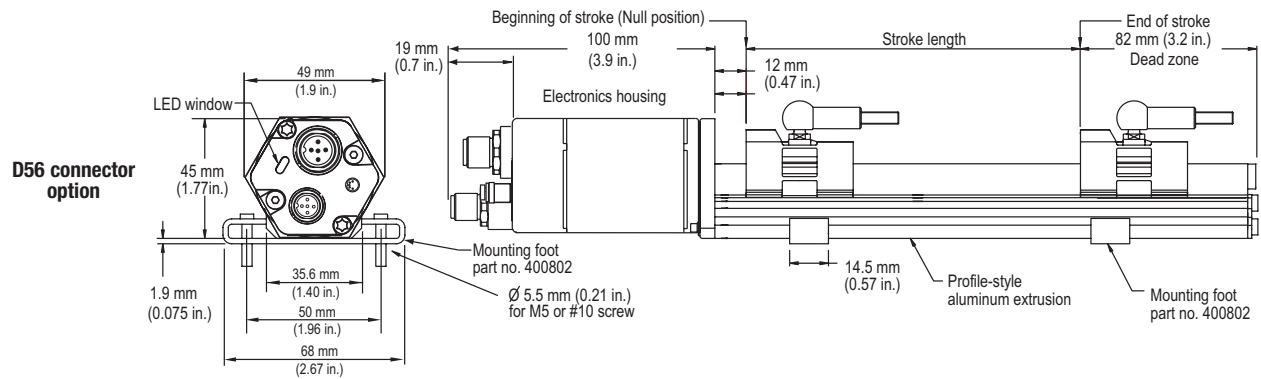

Floating magnet (open ring)

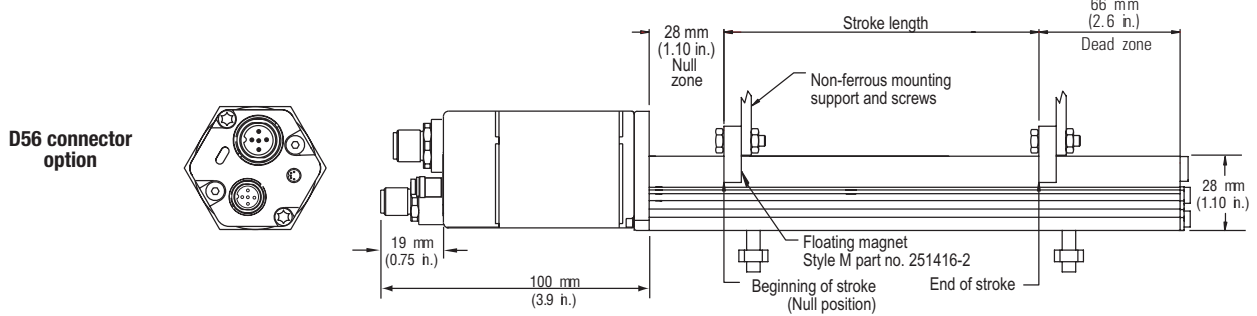

Model RH rod-style sensor

The Temposonics R-Series rod-style sensor (Model RH) offers modular construction, flexible mounting configurations, and easy installation. It is designed for internal mounting in applications where high pressure conditions exist, (5000 psi continuous, 10,000 psi spike), such as hydraulic cylinders. The Model RH sensor may also be mounted externally in many applications.

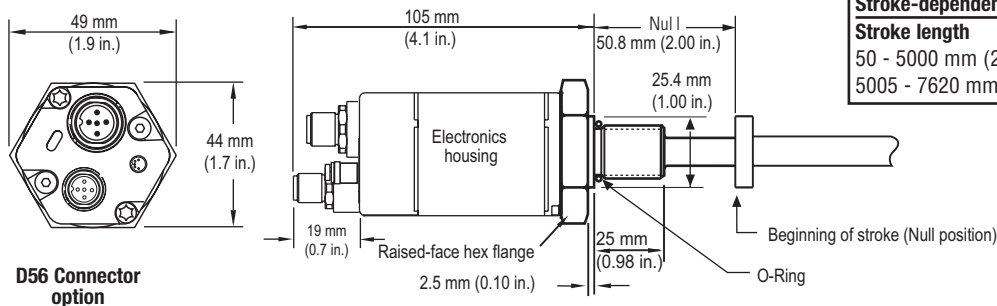
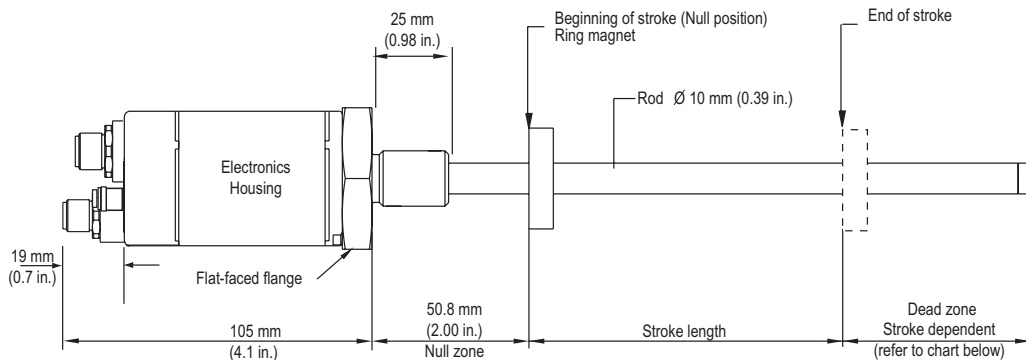

Stroke-dependent Dead Zones	
Stroke length	Dead Zone
50 - 5000 mm (2 - 197 in.)	63.5 mm (2.5 in.)
5005 - 7620 mm (197.1 - 300 in.)	66 mm (2.6 in.)

How to order

R											1	E			
1	2	3	4	5	6	7	8	9	10	11	12	13	14	15	16

SENSOR MODEL

RP = Profile style
RH = Hydraulic rod style

HOUSING STYLE

Model RP sensor only (magnet included):
S = Captive-sliding magnet with joint at top (part number 252182)
V = Captive-sliding magnet with joint at front (part number 252184)
M = Floating magnet open ring (part number 251416-2)

Models RH sensor only (magnet must be ordered separately):
T = US customary threads, raised-faced hex, and pressure tube
S = US customary threads, flat-faced hex, and pressure tube
M = Metric threads, flat-faced hex, and pressure tube
B = Sensor cartridge only (No pressure tube, stroke lengths ≤ 72 in.).

STROKE LENGTH

--- **M** = Millimeters (Encode in 5 mm increments)
 --- **U** = Inches and tenths (Encode in 0.1 in. increments)

CONNECTION TYPE

D56 = 2 x 5 pin, male/female (M12), plus 4-pin male (M8).

INPUT VOLTAGE

1 = +24 Vdc (+20%, -15%)

OUTPUT

E ___ = Profibus protocol (Fill in the three blanks with the following codes):

101 = Single magnet (standard)
102 = Position, velocity (max. 4 positions/velocities)

Stroke length notes:
 RH stroke range = 50 - 7620 mm (2 - 300 in.)
 RP stroke range = 50 - 5080 mm (2 - 200 in.)